

CMT83086 High Reliability Isolated Full - Duplex RS-485 Transceivers

1 Features

- Safety-related certifications
 - DIN VDE V 0884-11: 2017-01
 - UL recognition: up to 5000Vrms for 1 minute per UL1577
 - CSA component notice 5A
 - CQC approval per GB4943.1-2011
- Up to 5000Vrms Insulation voltage
- Bus side power supply voltage: 3.0V to 5.5V
- VDD1 supply voltage: 2.5 to 5.5 V
- High CMTI: $\pm 200\text{Kv/us}$
- High system level EMC performance:
- Bus Pins meet IEC61000-4-2 $\pm 12\text{ kV ESD}$
 - Other Pins meet $\pm 7\text{ kV contact ESD}$
 - Operation temperature: -40°C to 125°C
- Fail-safe protection receiver
- Slew rate limitation
- Robust isolation barrier life:
 - More than 40-year projected lifetime
- Up to 256 transceivers on the bus
- RoHS-compliant packages: SOIC 16 (wide body)

2 Applications

- Industrial automatic control
- Isolated RS-485 communication
- Smart electric meter and water meter
- Security and protection monitoring

3 Description

CMT83086 is a high reliability isolated full duplex RS-485 transceiver based on CMOSTEK digital isolation technology. It is safety certified by UL1577 support 5kVrms insulation withstand voltages, while providing high electromagnetic immunity and low emissions at low power consumption.

The Bus pins of CMT83086 is protected from $\pm 12\text{kV}$ system level ESD to GND2 on Bus side. These devices feature fail-safe circuitry, which guarantees a logic-high receiver output when the receiver inputs are open or shorted. The devices have a 1/8-unit-load receiver input impedance that allows up to 256 transceivers on the bus.

The data rate of CMT83086 is 12Mbps. The device is slew limited to reduce EMI and reflections with improperly terminated transmission line.

The CMT83086 is available in wide-body (WB) 16-pin SOIC packages.

Device Information

Part No.	Package	Body Size (mm x mm)
CMT83086	WB(W) SOIC-16	10.4 x 7.5
Refer to section 12 for ordering information.		

Functional Block Diagram

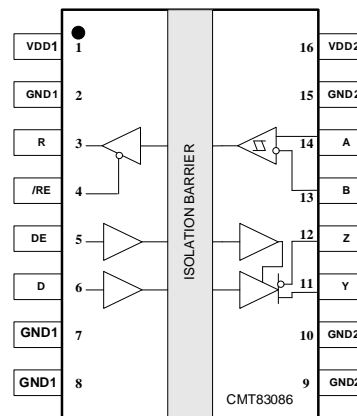

Table of Contents

1 Features	1
2 Applications	1
3 Description	1
4 Absolute Maximum Ratings	3
5 Pin Description	4
6 Typical Application	5
6.1 Typical Application Schematic	5
6.2 PCB Layout Guidelines	5
6.3 ESD Protection	6
6.4 256 Transceivers on the Bus	6
7 Parameter Measurement Circuit Setup	6
8 Specifications	9
8.1 DC Electrical Characteristics	9
8.2 Switching Electrical Characteristics	10
8.3 Insulation Specifications	11
8.4 Typical Performance	12
9 Safety-related Certifications	14
10 Function Description	15
10.1 Function Overview	15
10.2 Data Rate	15
10.3 True Fail-safe Receiver Inputs	15
10.4 Truth Tables	15
10.5 Thermal Shutdown	16
11 Packaging Information	16
11.1 CMT83086 Wide Body SOIC-16 Packaging	16
12 Ordering Information	18
13 Tape and Reel Information	19
14 Revise History	21
15 Contacts	22

4 Absolute Maximum Ratings

Table 1. Absolute Maximum Ratings⁽¹⁾

Parameters	Symbol	Condition	Min.	Max.	Unit
Power supply voltage ⁽²⁾	VDD ₁ , VDD ₂		-0.5	6	V
Maximum input voltage	/RE, DE, TxD		-0.4	VDD+0.4	V
Common-mode transients	CMTI			200	kV/us
Driver Output/Receiver Input Voltage	VA, VB, VY, VZ		-7	12	V
Receiver output current	IO		-15	15	mA
Maximum surge isolation voltage	VIOSM			8	kV
Operating temperature	Topr		-40	125	°C
Storage temperature	T _{STG}		-40	150	°C
Electrostatic discharge	HBM (Bus pins and GND)			±8000	V
	HBM (All pins)			±6000	V
	CDM			±2000	V

5 Pin Description

The pin list is shown as below.

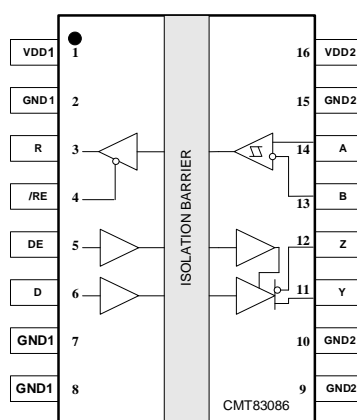

Figure 1. CMT83086 Pin List

Pin No.	Symbol	Description
1	VDD1	Power Supply for Isolator Side 1
2	GND1	Ground reference for Isolator Side 1
3	R	Receive output
4	/RE	Receive enable input. This is a low level input.
5	DE	Driver enabled input. This is a high level input
6	D	Driver transmitting data input.
7	NC	Ground reference for Isolator Side 1
8	GND1	Ground reference for Isolator Side 1
9	GND2	Ground reference for Isolator Side 2
10	GND2	Ground reference for Isolator Side 2
11	Y	Noninverting Driver Output. When the driver is disabled, or when VDD1 or VDD2 is powered down, Pin Y is put into a high impedance state to avoid overloading the bus.
12	Z	Inverting Driver Output. When the driver is disabled, or when VDD1 or VDD2 is powered down, Pin Z is put into a high impedance state to avoid overloading the bus.
13	B	Inverting Driver Receiver Input.
14	A	Noninverting Receiver Input.
15	GND2	Ground for Isolator Side 2
16	VDD2	Power Supply for Isolator Side 2

6 Typical Application

6.1 Typical Application Schematic

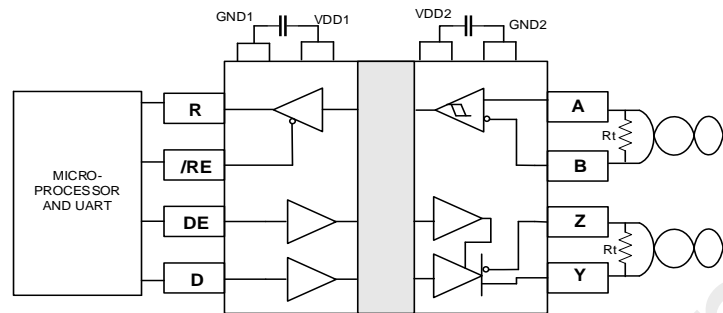
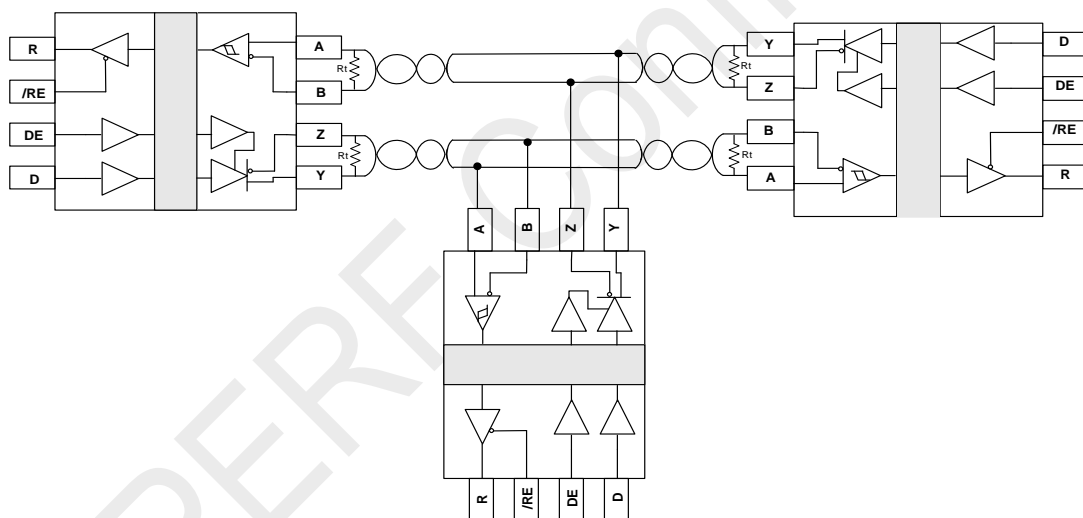

Figure 2. Typical Application Circuit



Note: R_t is a special matching impedance with typical value of 120 Ω .

Figure 3. Typical Isolated Full-duplex RS-485 Application

6.2 PCB Layout Guidelines

The CMT83086 requires a 0.1 μF bypass capacitor between VDD1 and GND1, 10 μF bypass capacitor between VDD2 and GND2. The capacitor should be placed as close as possible to the package. To eliminate line reflections, each cable end is terminated with a resistor, whose value matches the characteristic impedance of the cable. It's good practice to have the bus connectors and termination resistor as close as possible to the A and B pins.

6.3 ESD Protection

ESD protection structures are enhanced on all pins to protect against electrostatic discharge encountered during handling and assembly. The Bus pins have extra protection against static electricity to both the logic side (VDD1 side) and bus side (VDD2 side).

ESD protection can be tested in various ways. Below is the ESD spec of the devices. Bus pins:

- ± 8 kV HBM.
- ± 12 kV using the Contact Discharge method specified in IEC 61000-4-2

Other pins except bus pins:

- ± 6 kV HBM.
- ± 7 kV using the Contact Discharge method specified in IEC 61000-4-2

6.4 256 Transceivers on the Bus

The devices have a 1/8 unit-load receiver input impedance (96k Ω) that allows up to 256 transceivers on the bus. Connect any combination of these devices, and/or other RS-485 devices, for a maximum of 32 unit-loads to the line.

7 Parameter Measurement Circuit Setup

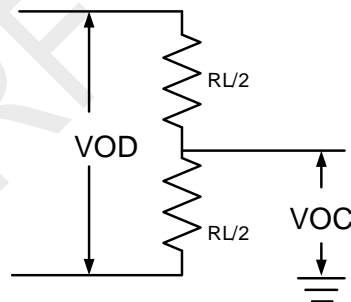

Figure 4. Driver DC Test Load

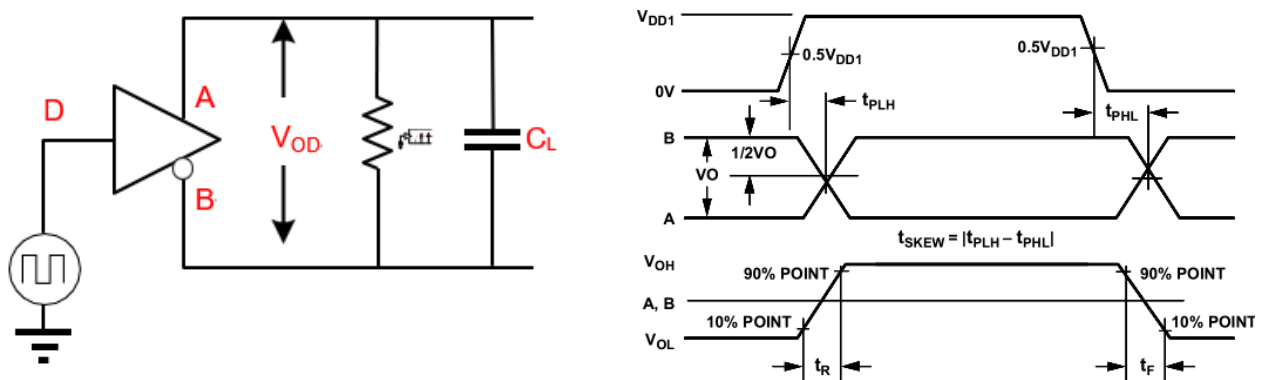

Figure 5. Driver Timing Test Circuit and Waveform

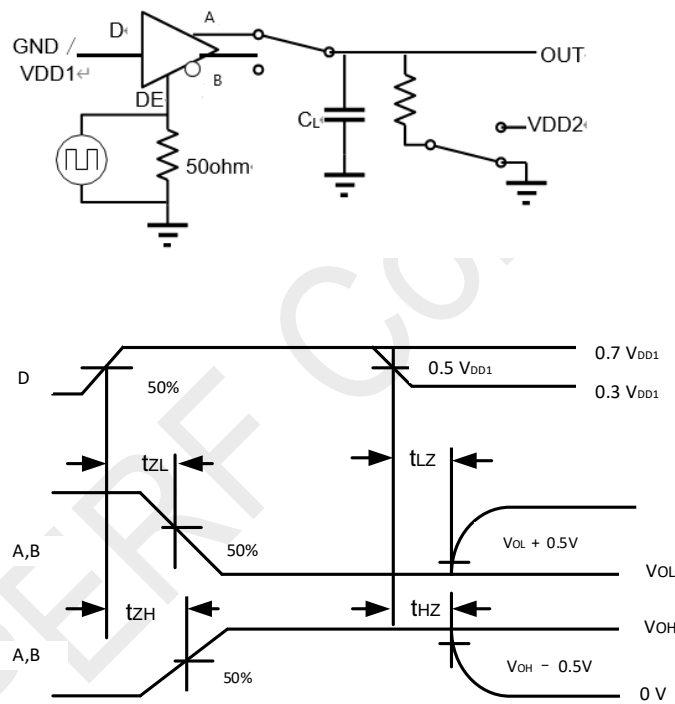

Figure 6. Driver Enable Disable Timing Test Circuit and Waveform

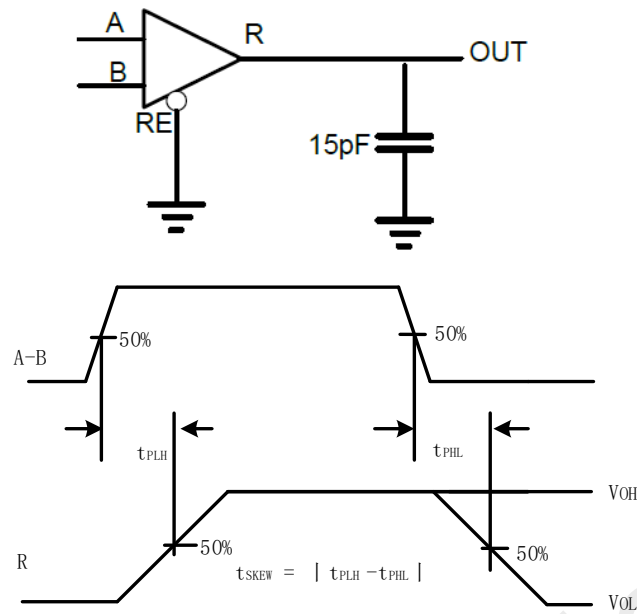

Figure 7. Receiver Propagation Delay Test Circuit and Waveform

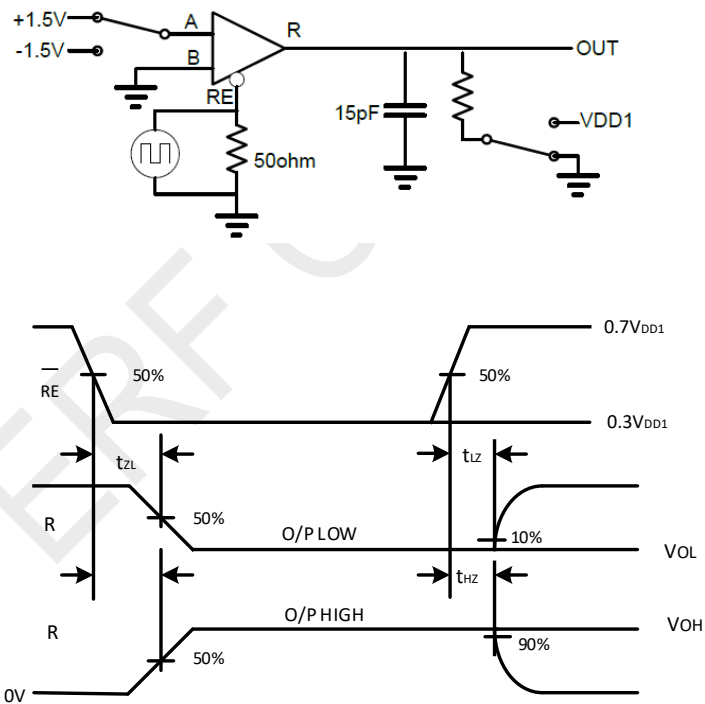

Figure 8. Receiver Enable Disable Timing Test Circuit and Waveform

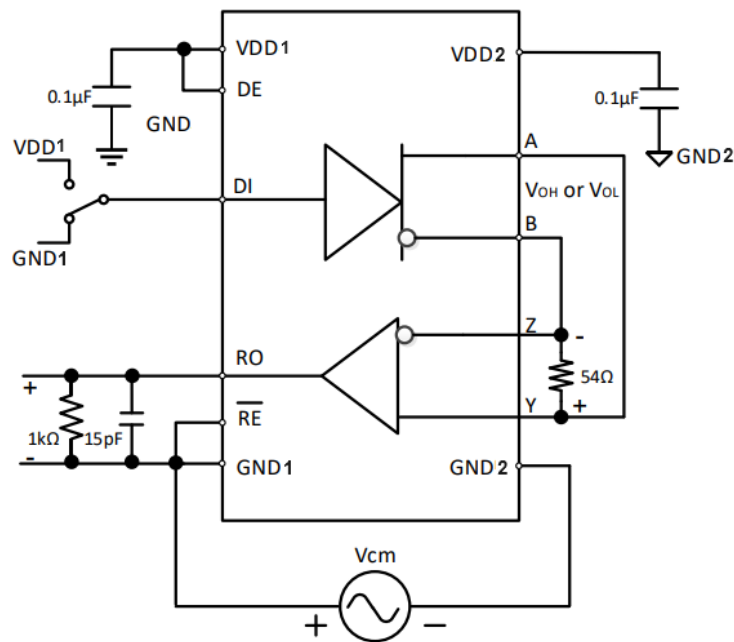

Figure 9. Common-Mode Transient Immunity Test Circuit

8 Specifications

8.1 DC Electrical Characteristics

VDD1 =2.5V~5.5V, VDD2= 3.0V~5.5V, TA= -40 to 125 °C. Unless otherwise noted, typical values are at VDD1=5V, VDD2=5V, TA=25 °C.

Table 3. Electrical Characteristics

Parameters	Symbol	Condition	Min.	Typ.	Max.	Unit
Supply Voltage	V _{DD1}		2.5		5.5	V
	V _{DD2}		3.0		5.5	V
Logic side supply current	I _{DD1}	VDD ₁ = 5 V, DE = high, /RE = D = low, no load		2.85	5.2	mA
		VDD ₁ = 3 V, DE = high, /RE = D = low, no load		2.81	5	
Bus side supply current	I _{DD2}	VDD ₁ = 5 V, DE = high, /RE = D = low, no load		2.1	5	mA
		VDD ₁ = 5 V, DE = high, /RE = D = low, no load		2.12	4.5	
Thermal-shutdown Threshold	T _{TS}			145		°C
Thermal-shutdown Hysteresis	T _{TSH}			15		°C
Common Mode Transient Immunity	CMTI				200	kV/us
Logic Side						
High level input voltage	V _{IH}	DE, D		1.65		V
		/RE		0.8		
Low level input voltage	V _{IL}	DE, D, /RE		1.65		V
		/RE		0.8		
Input threshold	V _{IT}	Input Threshold at rising edge		1.65		V
	V _{IT_HYS}	Input Threshold Hysteresis		0.2		

Input Pull up Current	I_{PU}	DI/RE			10	μA
Input Pull down Current	I_{PD}	DE	-10			μA
Output Voltage High	V_{OH}	$I_{OH} = -4mA$	$V_{DD1} - 0.3$			V
Output Voltage Low	V_{OL}	$I_{OL} = 4mA$			0.3	V
Output Short-Circuit Current	I_{OSR}	$0 \leq V_R \leq V_{DD1}$			109	mA
Three-State Output Current	I_{OZ}	$0 \leq V_R \leq V_{DD1}$, /RE = high	-15			μA
Input Capacitance	C_{IN}	DE, D, /RE		2		pF
Driver						
Differential output voltage	$ V_{OD} $	$V_{DD}=5V, TXD=0, R_{load} = 60\Omega$	2.4		V_{DD2}	V
		$R_L=100\Omega$ (RS-422)	3		V_{DD2}	
		$R_L=54\Omega$ (RS-485)	2.2		V_{DD2}	
Change in magnitude of the differential output voltage	$\Delta V_{OD} $	$R_L=100\Omega$ or $R_L=54\Omega$			0.2	
Common-Mode Output Voltage	$ V_{OC} $	$R_L=100\Omega$ or $R_L=54\Omega$		$V_{DD2}/2$	2.8	
Change in Magnitude of Common-Mode Voltage	$\Delta V_{OC} $	$R_L=100\Omega$ or $R_L=54\Omega$			0.2	V
Driver Short-Circuit Output Current	I_{OSD}	$0 \leq V_{OUT} \leq +12V$			100	mA
		$-7V \leq V_{OUT} \leq V_{DD2}$	-100			
Receiver						
Input Current (A and B)	I_A, I_B	DE=GND, $V_{DD2}=GND$ or $V_{DD2}, V_{IN}=12V$			80	μA
		DE=GND, $V_{DD2}=GND$ or $V_{DD2}, V_{IN}=-7V$	-60			
Receiver Differential Threshold Voltage	V_{TH}	$-7V \leq V_{CM} \leq 12V$	-200	-125	-50	mV
Receiver Input Hysteresis	ΔV_{TH}	$V_A+V_B=0$		40		mV
Receiver Input Resistance	R_{IN}	$-7V \leq V_{CM} \leq 12V, DE=low$	96k Ω			

8.2 Switching Electrical Characteristics

$V_{DD1} = 2.5V \sim 5V$, $V_{DD2} = 2.5V \sim 5.5V$, $T_A = -40$ to $85^\circ C$. Unless otherwise noted, Typical values are at $V_{DD1} = 5V$, $V_{DD2} = 5V$, $T_A = 25^\circ C$

Table 4. Switching Electrical Characteristics

Parameters	Symbol	Condition	Min.	Typ.	Max.	Unit
Driver						
Maximum Data Rate	f_{MAX}				12	Mbps
Driver Propagation Delay	t_{PLH}			11.5	50	ns
	t_{PHL}			13.2	50	ns
Driver Pulse Width Distortion, $ t_{PHL} - t_{PLH} $	PWD			1	10	ns
Driver Output Falling Time or Rising time	t_F			1.7	16	ns

	t_R			1.8	16	
Driver Enable to Output High	t_{ZH}			30	60	ns
Driver Enable to Output Low	t_{ZL}			30	60	ns
Driver Output High to Disable	t_{HZ}			18	60	ns
Driver Output Low to Disable	t_{LZ}			12	60	ns
Receiver						
Maximum Data Rate	f_{MAX}				12	Mbps
Receiver Propagation Delay	t_{PLH}	$C_L=15pF$		90	200	ns
	t_{PHL}	$C_L=15pF$		75	200	
Receiver Pulse Width Distortion	PWD	$C_L=15pF$		3	20	ns
Receiver Output Falling Time or Rising time	t_F	$C_L=15pF$		4.5	6	ns
	t_R	$C_L=15pF$		4.5	6	
Receiver Enable to Output High	t_{ZH}	$R_L=1k\Omega, C_L=15pF$		30	80	ns
Receiver Enable to Output Low	t_{ZL}	$R_L=1k\Omega, C_L=15pF$		30	80	ns
Receiver Disable to Output High	t_{HZ}	$R_L=1k\Omega, C_L=15pF$		18	60	ns
Receiver Disable to Output Low	t_{LZ}	$R_L=1k\Omega, C_L=15pF$		12	60	ns

8.3 Insulation Specifications

Table 5. Insulation Specifications

Parameters	Sym.	Condition	Value	Unit
External clearance ^[1]	CLR	The shortest terminal-to-terminal distance through air	8.0	mm
External creepage ^[1]	CRP	The shortest terminal-to-terminal distance across the package surface	8.0	mm
Distance through insulation	DTI	Minimum internal gap	26	um
Comparative tracking index	CTI	DIN EN 60112 (VDE 0303-11); IEC 60112	> 400	V
Material group	-		II 1	-
DIN VDE V 0884-11:2017-01^[2]				
Voltage Classification as standard of IEC 60664-1		For Rated Mains Voltage $\leq 150V_{rms}$	I to IV	
		For Rated Mains Voltage $\leq 300V_{rms}$	I to IV	
		For Rated Mains Voltage $\leq 300V_{rms}$	I to IV	

Pollution Degree per DIN VDE 0110			2	
Maximum repetitive isolation voltage	V_{IORM}		1414	V_{pk}
Maximum working insulation voltage	V_{IOWM}	AC voltage (sine wave); Dielectric layer breakdown (TDDB) test	1000	V_{RMS}
		DC voltage	1414	V_{pk}
Maximum transient isolation voltage	V_{IOTM}	$V_{TEST} = V_{IOTM}$, $t = 60$ s (certified); $t = 1$ s (100% production)	7000	V_{pk}
Maximum surge isolation withstand voltage [3]	V_{IOSM}	According to the IEC60065 test, 1.2/50 us waveform, $V_{TEST} = 1.6 \times V_{IOSM}$ (certified)	7000	V_{pk}
Apparent electric charge [4]	q_{pd}	Method a: after the security test subgroup, $V_{ini} = V_{IOTM}$, $t_{ini} = 60$ s; $V_{pd(m)} = 1.2 \times V_{IORM}$, $t_m = 10$ s	<5	pC
		Method a: after the environmental test subgroup1, $V_{ini} = V_{IOTM}$, $t_{ini} = 60$ s; $V_{pd(m)} = 1.6 \times V_{IORM}$, $t_m = 10$ s	<5	
		Method b1: General test (100% production) and preconditioning (test style) $V_{ini} = V_{IOTM}$, $t_{ini} = 1$ s; $V_{pd(m)} = 1.875 \times V_{IORM}$, $t_m = 1$ s	<5	
Insulation capacitance, from input to output ^[5]	C_{IO}	$f = 1$ MHz	0.8	pF
Isolation resistor, from input to output ^[5]	R_{IO}	$V_{IO} = 500$ V	$>10^9$	Ω
Input capacitance	C_I		2	pF
Total power consumption at 25 °C	P_S		1499	mW
Secure input, output, or supply current	I_S	$\theta_{JA} = 140$ °C/W, $V_I = 5.5$ V, $T_J = 150$ °C, $T_A = 25$ °C		mA
Isolation resistance, from input to output ^[5]	R_{IO}	$\theta_{JA} = 84$ °C/W, $V_I = 5.5$ V, $T_J = 150$ °C, $T_A = 25$ °C	237	Ω
Temperature	T_S		150	°C

8.4 Typical Performance

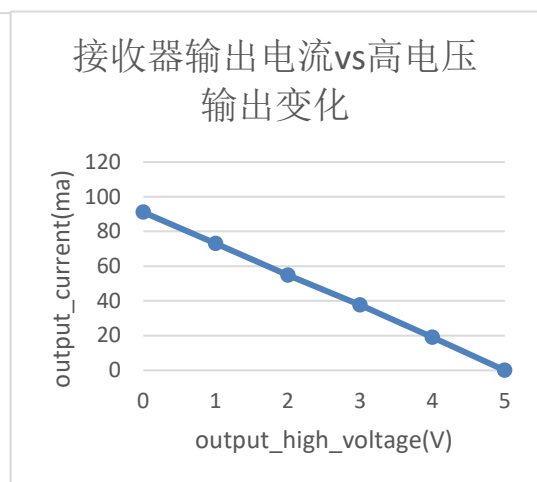
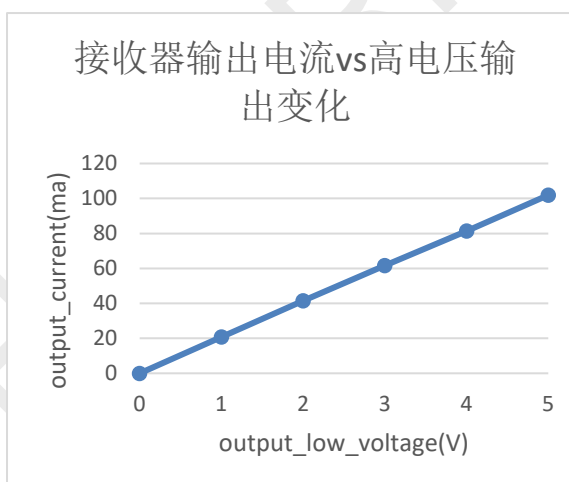
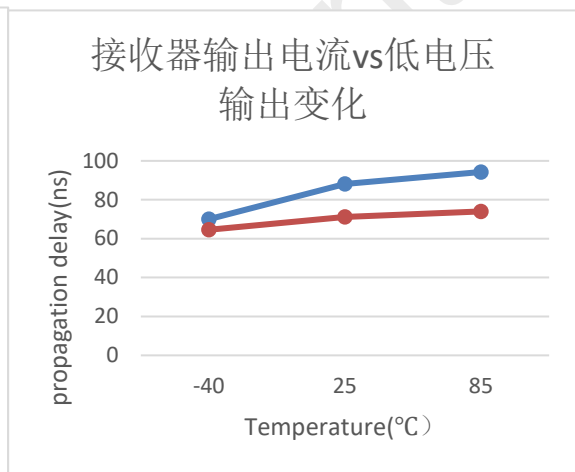
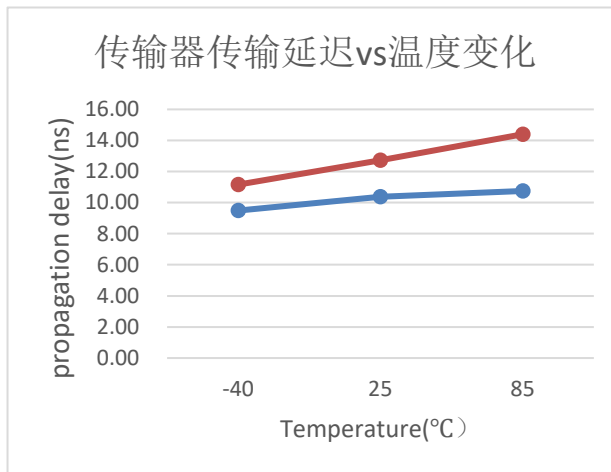
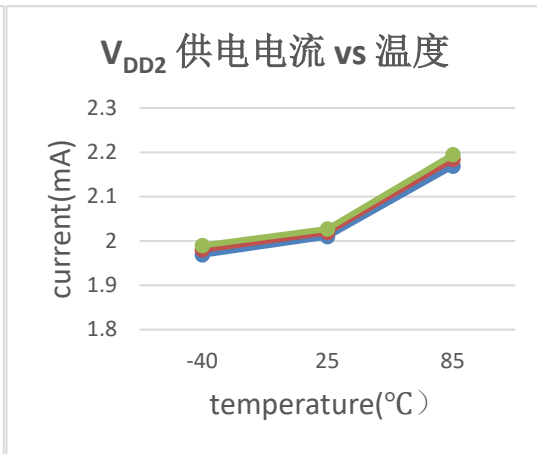
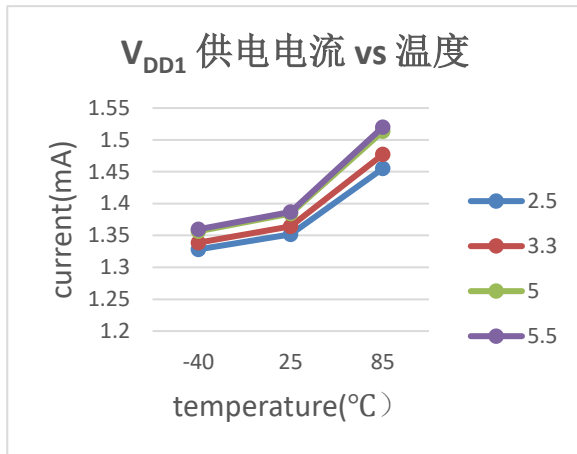

9 Safety-related Certifications

Table 6. Safety-related Certifications

VDE	CSA	UL	CQC
DIN VDE V0884-11:2017-01 (Patents pending)	IEC 60950-1, IEC 62368-1 and IEC 61010-1 (Patents pending)	Recognized under UL 1577 Component Recognition Program (Patents pending)	GB 4943.1-2011
Certificate number: pending	Master contract number: pending	File number: pending	Certificate number: pending

HOPERF Confidential

10 Function Description

10.1 Function Overview

CMT83086 is a high reliability isolated full duplex RS-485 transceiver. Data isolation is achieved using Cmostek integrated capacitive isolation that allows data transmission between the logic side and the Bus side. CMT83086 is safety certified by UL1577 support 5kVRMS insulation withstand voltages.

10.2 Data Rate

The data rate of CMT83086 is 12Mbps. The device is slew limited to reduce EMI and reflections with improperly terminated transmission line.

10.3 True Fail-safe Receiver Inputs

The devices feature fail-safe circuitry, which guarantees a logic-high receiver output when the receiver inputs are open or shorted. The receiver threshold is fixed between -50mV and -200mV, which meets EIA/TIA-485 standard. If the differential input voltage ($V_A - V_B$) is greater than or equal to -50mV, receiver output R is logic high. In the case of a terminated bus with all transmitters disabled, the differential input voltage is pulled to zero by the termination resistors. Due to the receiver threshold, the receiver output R is logic high.

10.4 Truth Tables

Table 7. Driver Function Table^[1]

VDD1	VDD2	Input (D)	Enable Input (DE)	Output (OUTx)	
				A	B
PU	PU	H	H	H	L
PU	PU	L	H	L	H
PU	PU	X	L	Z	Z
PU	PU	X	OPEN	Z	Z
PU	PU	OPEN	H	H	L
PD	PU	X	X	Z	Z
PU	PD	X	X	Z	Z
PD	PD	X	X	Z	Z

Table 8. Receiver Function Table

VDD1	VDD2	Differential Input ($V_A - V_B$)	Enable Input (/RE)	Output(R)
PU	PU	$\geq -50\text{mV}$	L/Open	H
PU	PU	$\leq -200\text{mV}$	L/Open	L
PU	PU	OPEN/SHORT	L/Open	H
PU	PU	X	H	Z

PU	PU	IDLE	L	H
PD	PU	X	X	Z
PU	PD	X	X	H
PD	PD	X	X	Z

1. PD= Powered down; PU= Powered up; H= Logic High; L= Logic Low; X= Irrelevant; Z= High Impedance.

10.5 Thermal Shutdown

The device is protected from over temperature damage by integrated thermal shutdown circuitry. When the junction temperature (T_J) exceeds +165°C (typ), the driver outputs go high-impedance. The device resumes normal operation when T_J falls below +145°C (typ).

11 Packaging Information

The packaging information of the CMT83086 SOIC16 is shown in the figures below.

11.1 CMT83086 Wide Body SOIC-16 Packaging

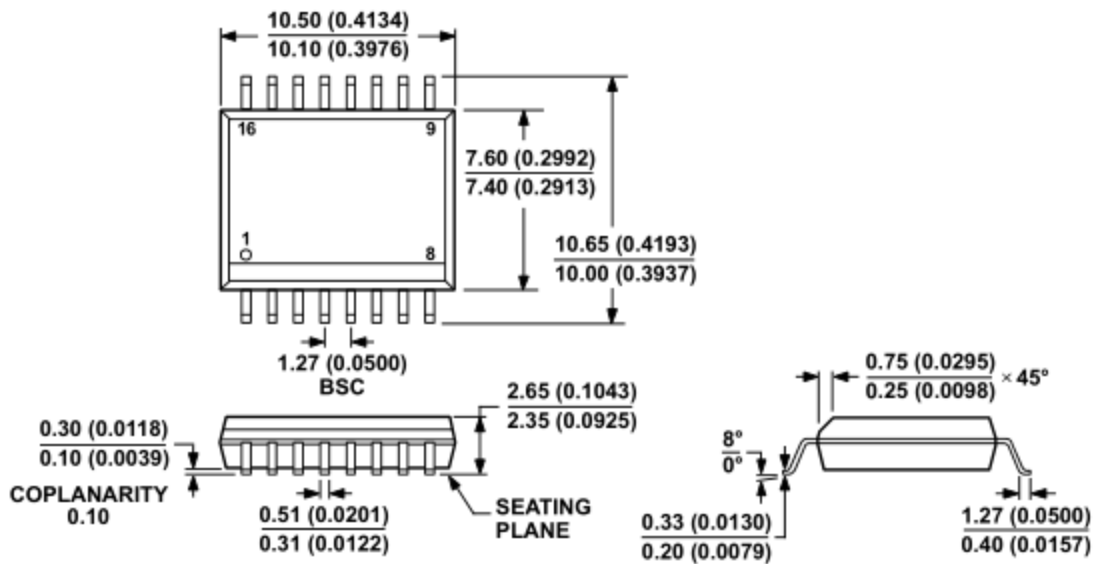

Figure 2. Wide Body SOIC-16 Packaging

Table 2. Wide Body SOIC-16 Packaging Scale

Symbol	Scale (mm)		
	Min.	Typ.	Max.
A	-	-	2.65
A1	0.10	0.20	0.30
A2	2.25	2.30	2.35

Symbol	Scale (mm)		
	Min.	Typ.	Max.
A3	1.00	1.05	1.10
b	0.35	0.37	0.43
c	0.15	0.20	0.30
D	10.30	10.40	10.50
E	10.10	10.30	10.50
E1	7.40	7.50	7.60
e	1.14	1.27	1.40
L	0.65	0.70	0.85
L1	1.40		
θ	0	-	8°

12 Ordering Information

Table 3. Part Number List

Part Number	MOQ	Isolation Rating (kV)	Duplex	Number of nodes	MSL	Max Data Rate (Mbps)	Temperature range	Package
CMT83086	1000	5	Full	256	2	12	-40 to 125°C	WB SOIC-16

Please visit www.hoperf.com for more product/product line information.

Please contact sales@hoperf.com or your local sales representative for sales or pricing requirements.

13 Tape and Reel Information

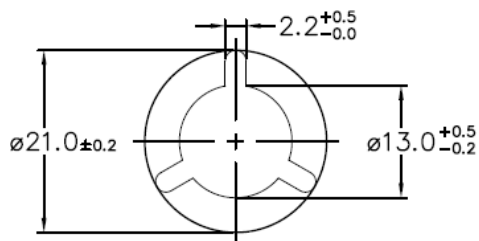
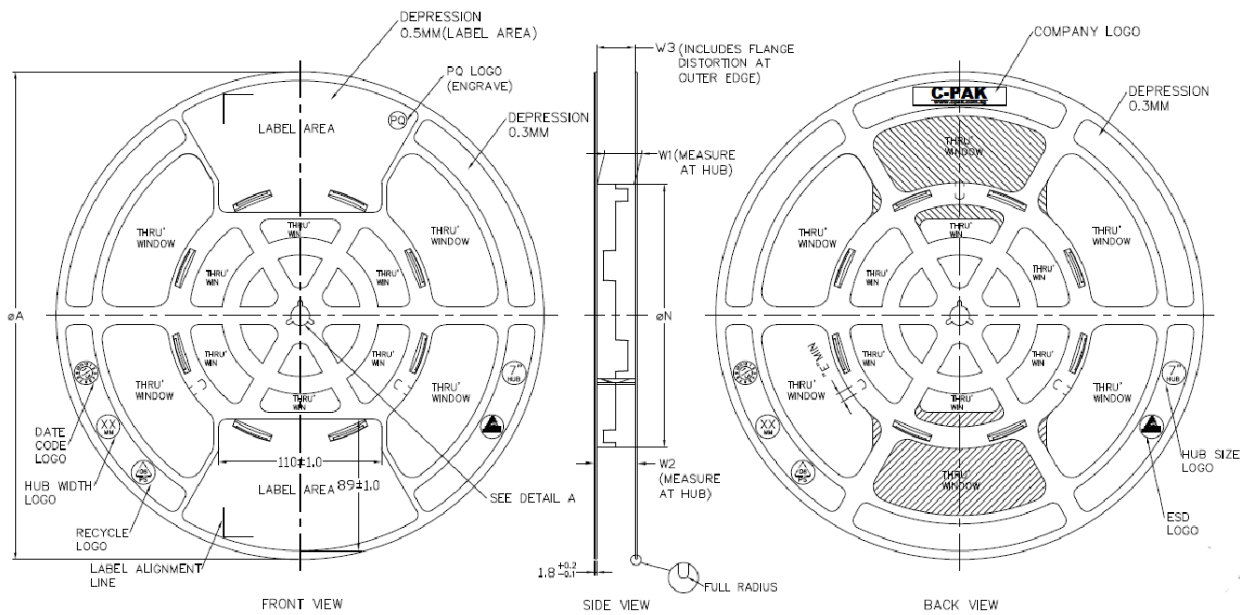

ARBOR HOLE
DETAIL A
SCALE : 3:1

PRODUCT SPECIFICATION						
TAPE WIDTH	∅A ±2.0	∅N ±2.0	W1	W2 (MAX)	W3	E (MIN)
08MM	330	178	8.4 ^{+1.5} _{-0.0}	14.4	SHALL ACCOMMODATE TAPE WIDTH WITHOUT INTERFERENCE	5.5
12MM	330	178	12.4 ^{+2.0} _{-0.0}	18.4		5.5
16MM	330	178	16.4 ^{+2.0} _{-0.0}	22.4		5.5
24MM	330	178	24.4 ^{+2.0} _{-0.0}	30.4		5.5
32MM	330	178	32.4 ^{+2.0} _{-0.0}	38.4		5.5

SURFACE RESISTIVITY			
LEGEND	SR RANGE	TYPE	COLOUR
A	BELOW 10 ¹²	ANTISTATIC	ALL TYPES
B	10 ⁹ TO 10 ¹¹	STATIC DISSIPATIVE	BLACK ONLY
C	10 ⁵ & BELOW 10 ⁵	CONDUCTIVE (GENERIC)	BLACK ONLY
E	10 ⁹ TO 10 ¹¹	ANTISTATIC (COATED)	ALL TYPES

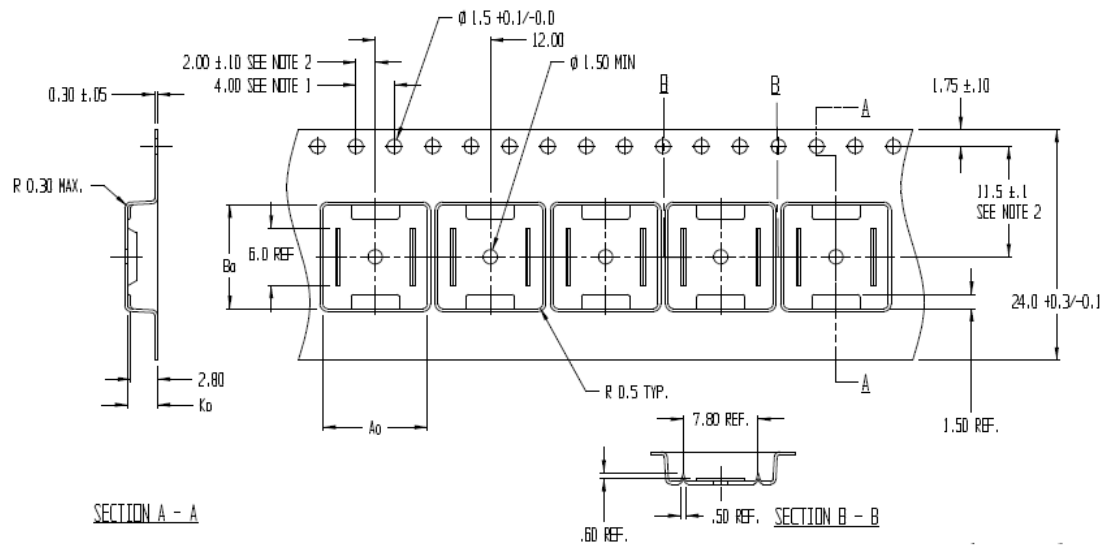

NOTES:

1. TO SPROCKET HOLE PITCH CUMULATIVE TOLERANCE ± 0.2
2. POCKET POSITION RELATIVE TO SPROCKET HOLE MEASURED AS TRUE POSITION OF POCKET, NOT POCKET HOLE
3. A_0 AND B_0 ARE CALCULATED ON A PLANE AT A DISTANCE "R" ABOVE THE BOTTOM OF THE POCKET.

$A_0 = 10.90$
 $B_0 = 10.80$
 $K_0 = 3.1$

Figure 17. CMT83086 WB SOIC-16 Tape and Reel Information

14 Revise History

Table 4. Revise Records

Version No.	Chapter	Description	Date
0.1	All	Initial version	2024/8/19

HOPERF Confidential

15 Contacts

Shenzhen Hope Microelectronics Co., Ltd.

Address: 30th floor of 8th Building, C Zone, Vanke Cloud City, Xili Sub-district, Nanshan, Shenzhen, GD, P.R. China

Tel: +86-755-82973805 / 4001-189-180

Fax: +86-755-82973550

Post Code: 518052

Sales: sales@hoperf.com

Website: www.hoperf.com

Copyright. Shenzhen Hope Microelectronics Co., Ltd. All rights are reserved.

The information furnished by HOPERF is believed to be accurate and reliable. However, no responsibility is assumed for inaccuracies and specifications within this document are subject to change without notice. The material contained herein is the exclusive property of HOPERF and shall not be distributed, reproduced, or disclosed in whole or in part without prior written permission of HOPERF. HOPERF products are not authorized for use as critical components in life support devices or systems without express written approval of HOPERF. The HOPERF logo is a registered trademark of Shenzhen Hope Microelectronics Co., Ltd. All other names are the property of their respective owners.